

C0000201

BLIND BENCHMARK PREDICTIONS OF NACOK AIR INGRESS TESTS USING COMPUTATIONAL FLUID DYNAMICS

Marie-Anne Brudieu
Department of Nuclear Engineering
Massachusetts Institute of Technology

Andrew C. Kadak
Department of Nuclear Engineering
Massachusetts Institute of Technology

Abstract

MIT has been benchmarking Japanese and German NACOK air ingress tests using the FLUENT code for approximately three years [1]. The first benchmark study was for Japan Atomic Energy Research Institute's (JAERI) isothermal and non-isothermal experiments [2] which investigate molecular diffusion of N₂, and He under isothermal and natural circulation conditions, respectively. Another set of benchmark studies [3] was performed for JAERI's multi-component experiment which examines the combined effects of natural convection and air ingress, graphite oxidation, diffusion of gas mixture consisting of O₂, CO, CO₂, N₂, and He, and multi-component chemical reactions. This work demonstrated that the three fundamental physical phenomena of diffusion, natural circulation and then chemical reactions can be effectively modeled using computational fluid dynamics.

The NACOK test facility at the Julich Research Center has run several experiments over the past three years. The first was a series of natural circulation experiments [4] conducted in air which employed a hot and cold channel with ceramic pebbles. MIT was able to successfully benchmark its FLUENT methodology against these tests with good results. The latest series of tests conducted at the NACOK facility were two graphite corrosion experiments: The first test consisted of an open chimney configuration heated to 650°C with two pebble bed zones of graphite pebbles. The second test is a similar test with cold leg adjacent to the hot channel with an open return duct below the hot channel. Natural circulation, diffusion and graphite corrosion were studied for both tests. Using and adapting previous computational methods, MIT is using the FLUENT code to model these air ingress events in a blind test of the methodology. The objective is to compare these blind test predictions with the actual data and modify the model to improve predictive capability to develop a benchmarked analysis capability and improve understanding of the phenomenon during an air ingress event.

I. Introduction

The safety of High Temperature Gas-cooled Reactors (HTGRs), is recognized as a significant attribute of this type of reactor. Indeed, one of the most interesting features of these reactors lies in the fact that they do not need complex emergency cooling systems. In all accident situations, the heat can be removed by natural circulation without active systems. An important accident scenario that some raise as a concern about graphite moderated reactors is the issue of the potential for a fire caused by air ingress events. .

In this type of accident, a break in the primary circuit, for instance a coaxial pipe between the reactor vessel and the power conversion system, allows the ingress of surrounding air in the reactor core. The air reacts with the graphite of the reflector as well as the graphite of the fuel pebbles in a complex set of exothermic and endothermic reactions. The species produced are mainly CO (Carbon monoxide) and CO₂ (Carbon dioxide).

The key issue in this situation is to be able to predict what damage will be done to the graphite, the overall reactor structure and the fuel. It is also essential to know temperatures reached and estimate the amount of CO produced as well as the amount of oxygen available in the reactor to determine whether “burning” occurs. Once known and understood, an estimate could be made on the risk of graphite burning compared with the risk on a “simple” chemical corrosion.

Various experimental and computational studies of the overall problem were performed over many years. [4][5][8][9] These studies try ultimately to take in account all the parameters of the accident and several complex effects: dynamics, onset of natural circulation, temperature distribution, diffusion, heterogeneous and homogeneous chemical reactions depending on temperature and species distributions, heat transfer and removal, chemical species and mass transport.

The purpose of this paper is to go one step further using FLUENT, [1] a computational fluid dynamic (CFD) commercial tool, to simulate air ingress accidents in pebble bed reactors.

Firstly, air ingress accidents and FLUENT are presented, as well as the benchmarking work done previously by MIT on the JAERI air ingress experiments performed in Japan. [9] This provides

the reader with a thorough understanding of the different physical phenomenon taking place during air ingress and a foundation from which to proceed.

This paper then describes specific test configurations and experimental procedures of the two most recent air ingress tests at the NACOK facility, in the German Julich Center.

The paper continues by a detailing of a more complete and adaptable FLUENT base model that was developed to “blind” benchmark these experiments. This benchmarking is “blind” in that only the initial experimental configuration is known but no results were provided to aid in the development of the FLUENT model. The purpose was to determine whether the analytical procedures and modeling assumptions could be reliably used for predicting the progression of air ingress events on real reactors.

The results presented at the end of the paper vary in complexity depending on the phenomenon taken in account: the natural circulation physics of the model were validated based on previous known NACOK experiments with different configurations. [3] Qualitative two dimensional runs allow a good development and understanding of the chemical aspect of the model. Natural circulation computations as well as chemistry study on partial configurations are presented. Results from three dimensional simulations covering the complete problem with diverse chemical models are also compared in steady state computations.

II. Air Ingress Accidents

In the case of a LOCA, the first stage of the accident is a loss of helium with depressurization. This occurs until atmospheric conditions are reached. In the mean time, there is a rise in the core temperature. This rise is slow due to the fact that graphite has a tremendous capability to store and transfer heat. There is no air ingress in the core as long as the inside helium pressure remains higher than the outside atmospheric pressure. Once the outside and inside pressures are at equilibrium, helium being lighter than air, the latter can enter the core very slowly by molecular and thermal diffusion.

This process can take a very long time, depending on the location of the break and overall reactor condition. As air enters in contact with hot graphite, chemical exothermic and endothermic oxidation reactions occur. Multidimensional localized natural convection will enhance species transport. Due to the reactions, the temperature of the incoming gas rises and its density therefore decreases. Buoyancy forces

increase with the temperature gradient. This leads at some point to the onset of natural convection. For instance, in the case of a coaxial pipe break, this physical mechanism leads to air entering the reactor core, rising up to the top and going out through the breach of the outer tube of the coaxial pipe.

The circulation of air then cools the reactor down (passive cooling system). However, it also brings a supply of fresh air with oxygen, allowing more oxidation of the graphite to occur. A major issue is then to determine the temperature increase of the core as a combination of the heat stored in graphite, the energy deposited or removed by the endothermic and exothermic chemical reactions and the heat removed by convection. Knowing the temperature will help determine air ingress velocities, the concentrations of CO and CO₂ and ultimately whether the graphite might burn. The other important feature is therefore the corrosion of the structural graphite. It is vitally important to be able to predict the location and mass loss along with the total corrosion. The integrity of the structure as well as the evolution of its mechanical and thermal properties will strongly depend on how the structural graphite is chemically reacted.

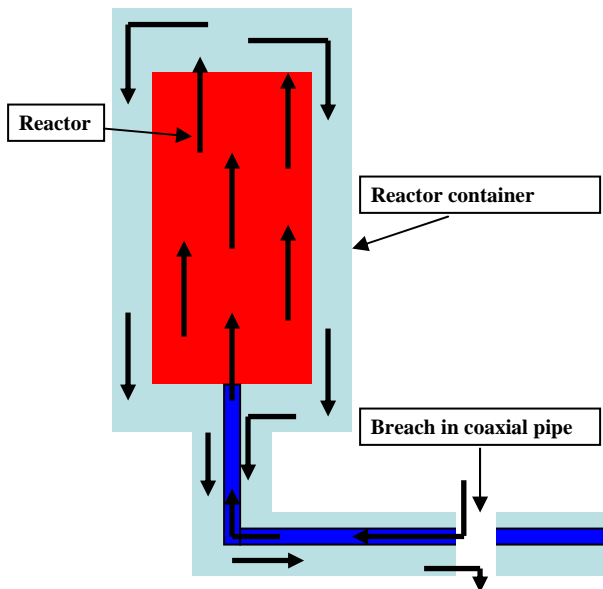

Figure 1
Natural circulation process after a break in a coaxial pipe

III. The CFD Tool FLUENT

III.1. FLUENT 6.2

FLUENT 6.2, used with the meshing software GAMBIT 2.2, is the world's largest commercial CFD software. Its main features include: complex geometry and meshing, multicomponent reacting flows (homogeneous and heterogeneous), mass diffusion, heat transfer and convection, User Defined Functions (UDF) for boundary conditions and flow features, and advanced postprocessing tools. Eventually, this code will be used to develop modeling of air ingress events in the Pebble Bed Modular Reactor. In order to accomplish this objective, the code has to be benchmarked with experiments. Two major experiments were modeled with FLUENT: the JAERI in Japan and the NACOK in Germany.

III.2. Overview of the Past Benchmarking of Fluent on the JAERI Experiments

MIT has already benchmarked FLUENT on the three JAERI air ingress experiments (Japanese Atomic Energy Research Institute). The experimental apparatus consisted of a reverse U-shaped tube and a gas tank. See Figure 2. A temperature gradient could be applied to the tube creating a hot and cold leg. A graphite tube could be inserted in the heated pipe section to simulate a reflector flow channel. The experiments simulated were isothermal experiments (to study diffusion), thermal experiment (to study onset of natural circulation with hot and cold legs) and a multi-component experiment with graphite and air ingress to study all phenomenon including chemical reactions.

A complete model was developed with FLUENT. The ideal gas database was used, the boundary conditions on wall were exterior temperature, and the multi-component model was adopted for diffusion process. Chemical reaction rates obtained from JAERI's recommendations were input as such in FLUENT with a fixed ratio of production of CO and CO₂ by graphite oxidation. The grid-adaptation option was used. Results and comparison with experimental data were very satisfying for diffusion, thermal and multi-component simulations.

This work showed that the FLUENT model and methodology is able to predict each separate physical phenomena occurring during air ingress accidents in a simple geometry quite well. Not only were the chemical reactions well modeled as a function of

time but also the onset of natural circulation. FLUENT's abilities to simulate air ingress accidents were also investigated by Lim and No [4] [5]. They also benchmarked it on small scale experiments with simple geometries and protocol ("two bulbs"

diffusion experiment, annular flow tube Takahashi's experiment, Circular flow tube Ogawa's experiment and the JAERI experiments). [8]

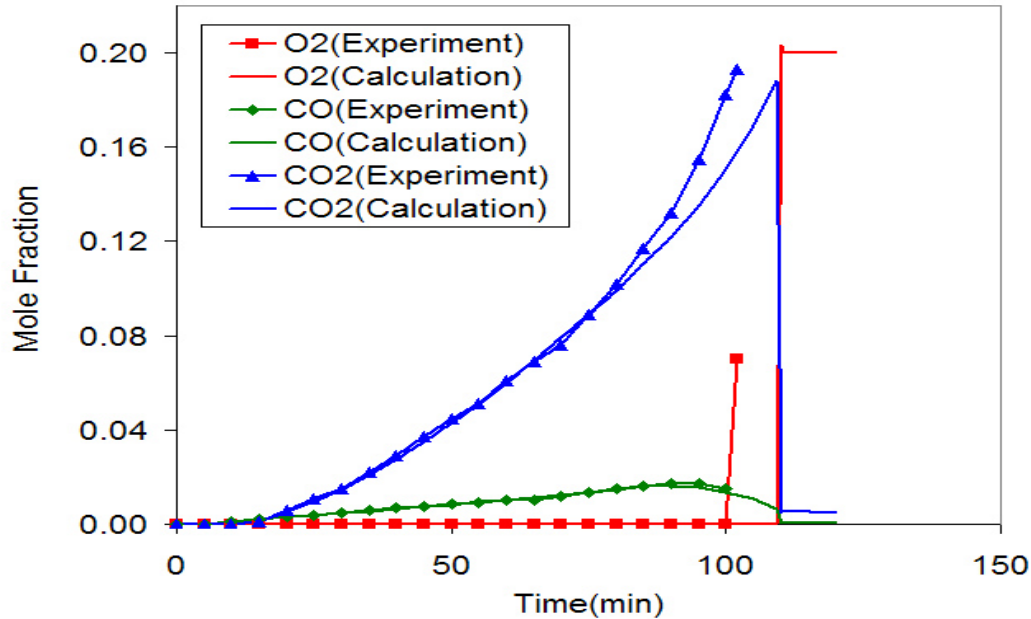

Figure 2

Example of good agreement between simulation and experiment on JAERI multi-component experiment [9]

III. The Nacok Natural Convection Corrosion Experiment

The NACOK experimental facility was designed more than 13 years ago at the Julich Research Center in Germany to study the effects of airflow driven by natural convection in the event of the complete rupture of the coaxial hot gas duct. The main goals were to determine, the onset time of convection, the mass flow and the locally dependant corrosion of graphite by having a full scale structure of 7.5 m high at a maximum temperature of 1200C.

Several series of experiments have been run at this facility in the past. The first series of two types of test to be thoroughly documented were performed in 1999 and reported by Kuhlmann[3]. The first test was the study of natural circulation in a hot and cold leg (return duct set-up). The second test was an open chimney corrosion test simulating the lower reflector and graphite pebbles. The experiments were not tailored toward supplying exact data relevant to multicomponent experiments. Some uncertainties were raised: determination of reaction rates or species transfer mechanisms, temperature attained in the

corrosion zone, location of the corrosion, variation of the mass flow depending on the gas atmosphere, influence of various parameters on corrosion and mass flow and inleakage to the experimental apparatus. For all these reasons, these tests cannot provide reliable quantitative data, specifically on the chemical reactions impact. [7] The qualitative results are however of very high interest for a blind benchmarking. They allow us to check whether the qualitative computational results make sense.

The most recent series of tests were performed in March 2004 and July 2004. The first one being the open chimney corrosion test and the second, a return ducts corrosion test. These tests are not completely documented at this time, and it is the purpose of this section, to give an outline of their experimental configuration and procedures.

IV.1 Description of the Open Chimney Test (March 2004)

Configuration: The NACOK open chimney experiment is made of an open chimney heated to a uniform temperature of 650 °C by nitrogen. This temperature is maintained by wired heaters around

the chimney during the experiment. The heated internal walls are then maintained at this minimum temperature during the entire air ingress experiment. The interior of the rectangular chamber consists almost entirely of graphite.

The lowest part of the channel is the reflector. It is composed of two sets of ASR-1RS graphite blocks with vertical cylindrical holes of 40 mm and then 16 mm diameter. The properties of this graphite are very similar to the IG-110 used in Japan. Above the reflectors, there are two beds of pebbles (60mm and 30 mm diameter) made of A3-3 matrix graphite with heights 350 mm and 600 mm respectively. The porosity of the pebble beds are 0.395. Above the pebble bed is a long empty zone until the top of the chimney, at a height of 8316mm. A flow measurement device at the entrance of the channel

induces a given pressure drop that would not exist in natural conditions.

Experimental procedure: Initially, nitrogen at 650°C is blown into the experimental apparatus for a sufficiently long time to ensure that all components are at a thermal equilibrium of 650°C. . Once this occurs, the pressure is equalized with atmospheric pressure. At the time $t = 0s$, the entrance duct is open and air from the building is let in. Outside temperature and humidity as well as the input flow are recorded. These were stable over the duration of the experiment (Relative humidity of 29% and temperature of 20 C). Temperature sensors and gas composition analysis devices are placed all along the experimental channel for data recording.

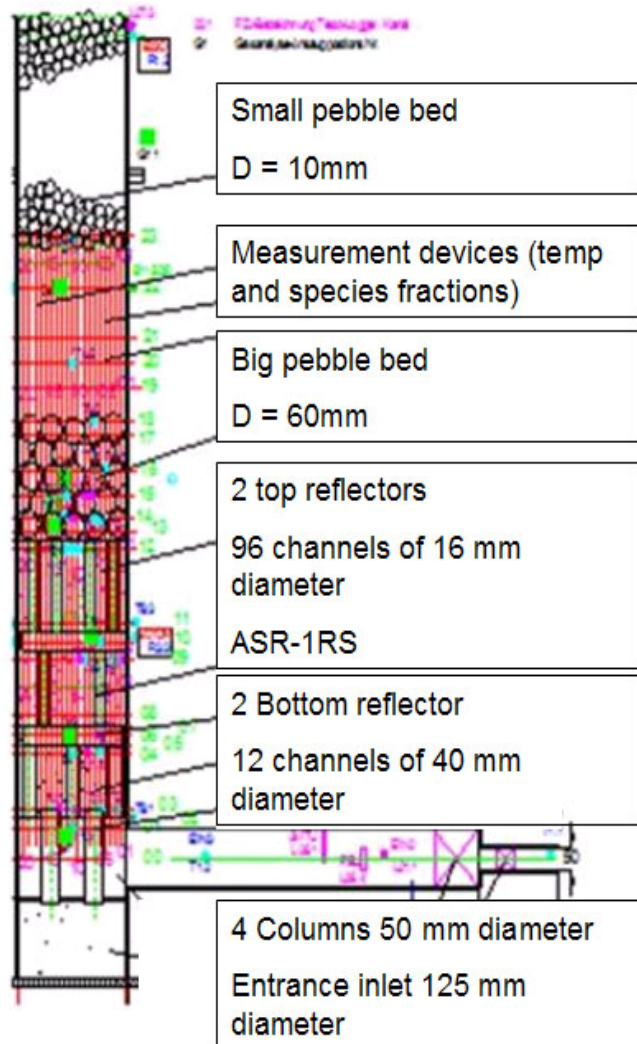

Figure 3
NACOK setting for open chimney experiments [7]

IV.2 Description of the Return-Duct Test (July 2004)

Configuration: The overall experimental setting is the same as the previous one. However, in these experiments, the top of the chimney is closed and the return duct of 125 mm diameter is set up as shown on the Figure 5 below. The height of the large pebbles bed is now 280 mm. That is smaller than in the open

chimney experiment and producing therefore a smaller pressure loss.

Experimental procedure: The channel is heated to a temperature of 650°C with nitrogen under slight pressure. It is then filled with helium and the pressure is equalized before the inlet duct is open. The cold leg is maintained at a temperature of 175°C.

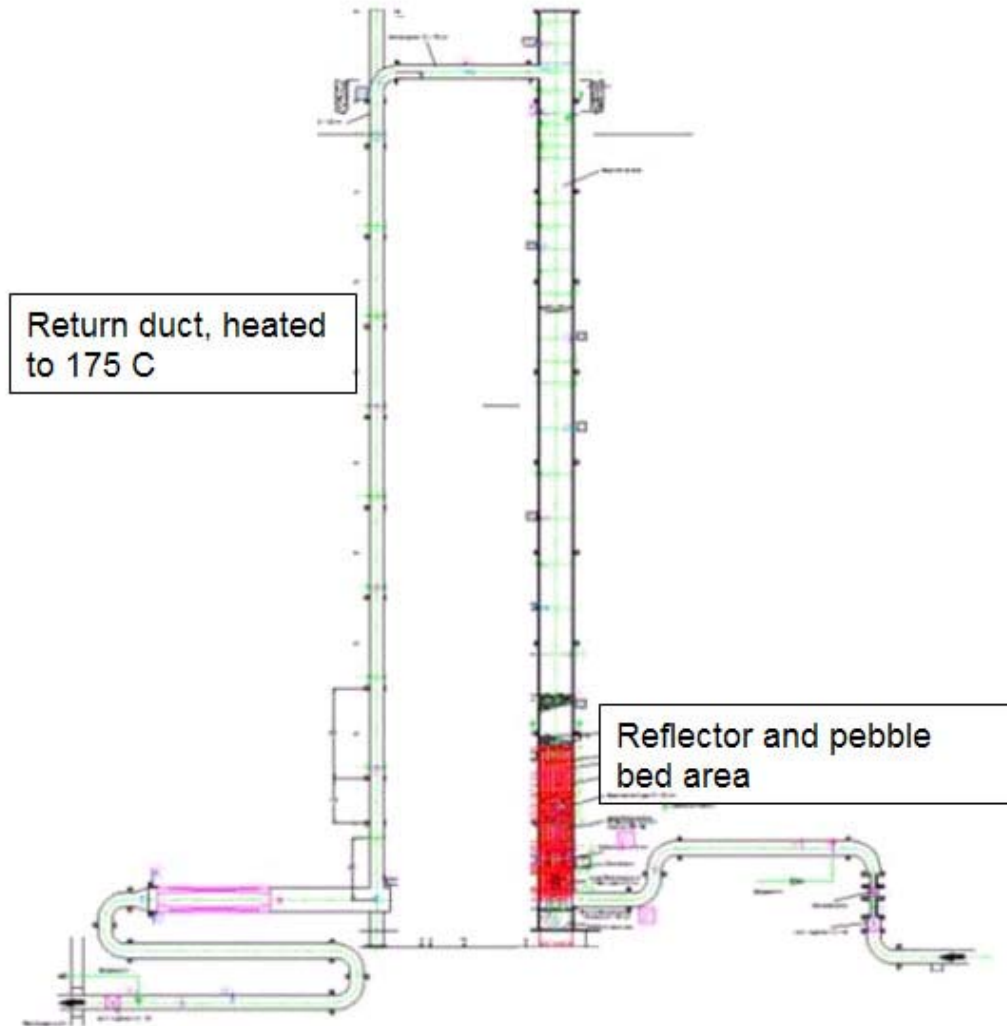

Figure 4
NACOK setting for return duct experiments [7]

V. FLUENT Computational Model for NACOK Simulations

This section summarizes the highlights of the FLUENT model developed.

The segregated laminar solver is used, either steady state or time dependant. For this flow, FLUENT solves the conservation equations for mass, momentum, energy and species. In this first simulation, the user's inputs include the geometry and meshing, the description of the pebble beds and graphite reflector as a porous media, the diffusion

model and parameters, the material (mixture) definition, chemical reactions, the physical model options in the solver and the convergence strategy.

V.1. The Pebble Beds

The pebbles can not be modeled separately. Therefore, they are assumed to be a porous media with a porosity of 0.395. In order to maintain the appropriate surface to volume ratio for chemical reactions, the surface area of the pore per unit volume is 60.42 for the 30 mm diameter pebbles and 30.21 for the 60 mm diameter pebbles. The physical velocity option is chosen in order to have better precision of the flow velocity in the porous media. A key input is the pressure drop created by the resistance to flow in the pebble bed. Kuhlman developed a correlation, based on the KTA report, [2]

for the pressure drop in the NACOK pebble bed reactor.

$$\frac{\Delta P}{\Delta H} = \psi * \frac{1 - \epsilon}{\epsilon^3} * \frac{1}{d} * \frac{1}{2\rho} * \left(\frac{\dot{m}}{A}\right)^2$$

And the parameter ψ for the NACOK experiment is such as:

$$\psi = \frac{505}{\text{Re}/1 - \epsilon} + \frac{0.1}{\left(\frac{\text{Re}}{1 - \epsilon}\right)^{0.1}}$$

Valid for $11 \leq \frac{\text{Re}}{1 - \epsilon} \leq 130$

This equation can then be converted in the proper format to be input in FLUENT via a User Defined Function (UDF) or by approximation in the FLUENT porous formulation.

Physical velocity Pressure drop correlation for a pebble bed of 60 mm diameter

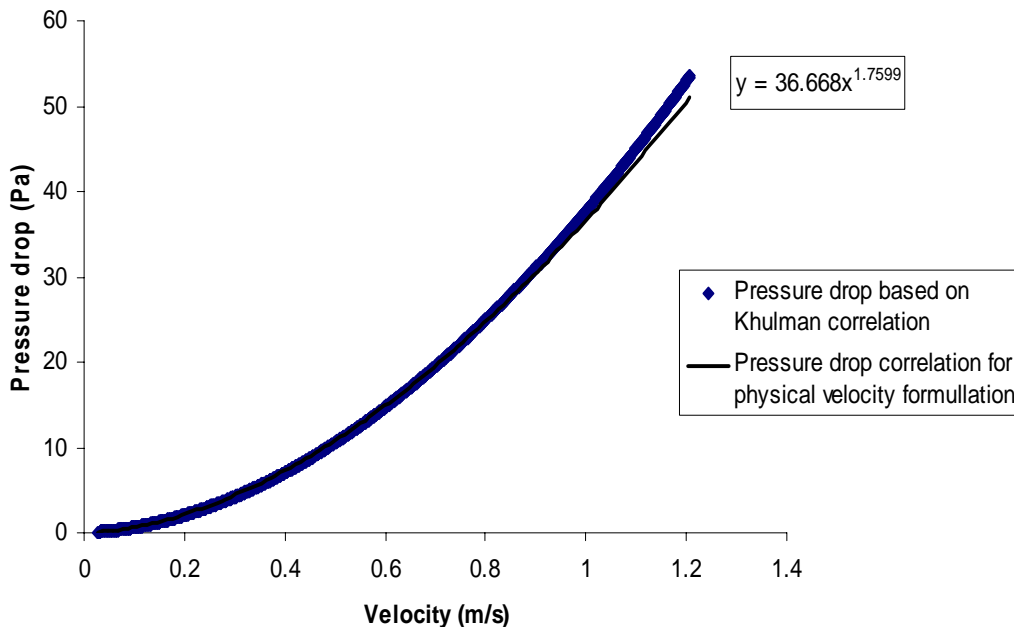

Figure 5
5 m high pebble bed pressure drop (Pa) vs. air flow velocity (m/s) as input in FLUENT

FLUENT offers two possibilities in dealing with velocity within the porous media: the superficial velocity and the physical velocity. The first one gives a velocity in the porous media equal to the velocity in the rest of the chimney. Experimental correlations are based on it. However, if one wants to take in account the real velocity in the porous media, which has a

strong impact on the chemical reaction rates, the physical velocity model must be turned on. ($V_{\text{physical}} = \text{porosity} * V_{\text{superficial}}$). Therefore, a correlation able to fit in the FLUENT porous physical velocity formulation was developed based on the pressure drop given by Kuhlman in the correct mass flow rate range. Every iteration, FLUENT calculates this pressure drop function to compute the momentum

equation in the pebble bed. The parameters used are local mechanical and thermodynamic properties of the fluid. The correlations used are: $\Delta P = 36.688 * v^{1.7599}$ for 60 mm diameter pebbles and $\Delta P = 81.08 * v^{1.678}$ for 30 mm diameter pebbles.

V.2 Reacting Gas Mixture

The mixture used is composed of N, H₂O, CO, C (solid), CO₂, He (depending on the experiment) and O₂. The materials that need to be modeled in this experiment include graphite (C), O, CO, CO₂, water vapor (H₂O), Nitrogen and Helium. The gas mixture at the inlet is composed of O₂, N and moisture (H₂O gas) given by NACOK data.

Diffusion is a major factor in these the experiments for several reasons. First, before the onset of natural convection in the return duct experiment, air reaches the core and the graphite by mass diffusion and will start to react with graphite. Secondly, in these ranges of temperatures, the oxidation reaction rate is limited by in pore diffusion. The in pore diffusion rate determines the graphite corrosion rate. At higher temperature, the limiting effect is the diffusion in the boundary layer. The preferred formulation is the full Multicomponent diffusion model. The Fickian approximation works mainly for flows with non changing composition. The diffusion coefficients are computed by FLUENT using the kinetic-theory with the ideal gas law activated.

V.3 Chemistry Models

The chemical models chosen are key decisions in the simulation of this air ingress accident. It is the formulation that is subject to the most variability. It is dependant on the material properties of the graphite. The oxidation of graphite has been studied widely over the last 50 years and many different correlations have been developed. The oxidation produces CO and CO₂, CO being the main product at high temperature (above 900°). CO can react again with oxygen to form CO₂. CO₂ can then undergo the endothermic Boudouard reaction at elevated temperatures.

There are three different kinetic regimes depending on the temperature of the media. The reaction rates vary with these regimes but also depend on the transfer and circulation of gases, on the recombination of O and CO and on the type of graphite oxidized.

The primary heterogeneous gas/graphite reactions in air/water ingress accidents are, with constants given at 18 °C and 0.1MPa [6]:

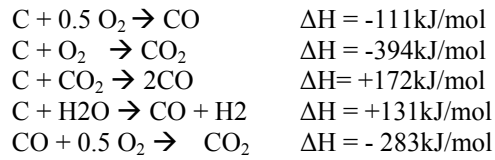

The following correlations were adapted to the FLUENT reaction rate input model.

The graphite oxidation correlation was used by Takeda and Hishida [8] and Lim and No [4][5] with different constants but following the same model:

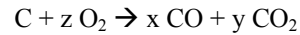

The reaction rate is described as,

$$r = K_0 * \exp \frac{E_1}{RT} P_{O_2}^n$$

Where:

$K_0=7500$ (kg/m².s) [4], $K_0=360$ (1/s.Paⁿ) [8]
 $E_0 = 218$ [4], $E_0=209$ [8] (kJ.mol⁻¹)
 N ranging from 0.5 to 1 depending on the partial pressure of O₂:

The ratio of CO and CO₂ is correlated as follows:

$$A = K_1 * \exp \frac{E_1}{RT} = \frac{x}{y}$$

where:

$K_1=7396$ [4], $K_1 = 7943$ [8]
 $E_1=69.604$ [4], $E_1= 78300$ [8] (kJ.mol⁻¹)

In that case,

$$\begin{array}{l} z=(A+2)/(2(A+1)) \\ x=A/(A+1) \\ y=1/(A+1) \end{array}$$

Figure 7 presents the variation of ratios with the temperature for these two models and with two other models issued from M.Rossberg [25].

In the fast running FLUENT model, the average fixed ratio used was: 58% CO and 42% CO₂. Otherwise, other models can be run with varying ratio using a UDF.

A Dryer and Glassman's correlation is used for the CO combustion [4][5].

$$R_{CO} = -r_{CO-O_2} * \rho * \left(\frac{\rho}{W_{O_2}}\right)^{0.25} * \left(\frac{\rho}{W}\right)^{0.5} * Y_{CO} * Y_{O_2}^{0.25} * X_{H_2O}^{0.5}$$

in kg/m³.s

with:

$$r_{CO-O_2} = 2.24 * 10^{12} * \exp\left(\frac{-167400}{RT}\right)$$

where:

Y is the mass fraction of the species
X is the mole fraction of the species
W is the molar of the species or gas mixture.

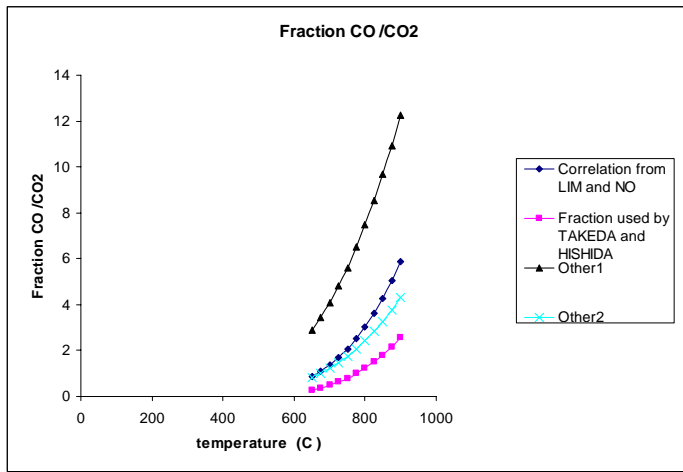

Figure 7
Variation of CO/CO₂ produced during graphite oxidation with temperature

The Boudouard reaction rate is taken as [4][5]:

$$r_c = \frac{0.145 \exp^{-25000 P_{CO_2} / T}}{1 + 3.4 * 10^{-5} \exp^{(7000/T) * P_{CO_2}^{0.5}}} \text{ in kg/m}^2\text{.s.}$$

The generation rates from each species can be determined as a sum of the rates of each reaction. They can be input this way with a UDF in FLUENT.

VI. Results

The results presented follow the methodology used in the development of the benchmarking procedure.

Results of several studies will be presented. These include (1) benchmarking the NACOK natural convection tests; (2) simulation of the NACOK open chimney and return duct flows without chemical reactions; (3) a study of graphite corrosion in the lower reflector; and finally: (4) the blind benchmark analysis of the NACOK open chimney experiment.

VI.1 Natural Convection Flow Experiments Benchmarking

In order to check the capacity of FLUENT to model natural convection flow and pebble bed induced pressure drop, the natural flow experiments run in 2001 [3] were used to benchmark the flow model. This new model needed to be benchmarked since it was different than that developed by Zhai [9] in that it used the physical velocity option instead of the superficial velocity for porous media as explained above.

Set up: The height of the pebble pile was h=5m; the total height of the test stand, critical for the lift, was H = 7.3m. To create the broadest possible data base, four temperature steps were chosen for the return pipe at an interval of 200 K each, up to the maximum heat value of 800°C. The temperature in the experimental channel was at least 50 K higher and was then increased in 50 K steps up to the maximum heating temperature. As expected, the convection flow developed due to the balance between the buoyancy forces (density driven) and the pressure drop in the pebble bed (function of the dynamic viscosity).

The FLUENT model used the physical velocity formulation based on the Kuhlman pressure drop correlation for the pebble bed modeled as a porous media. Temperature dependence of the density and the viscosity were taken in account using the ideal gas law and the kinetic theory.

Figure 7 and 8 show a good agreement between the experiments and the simulation, when comparing the physical and superficial velocity, especially for lower mass flow rates. The discrepancy in the higher mass flow rates might be due to the loss of flow reported in this experiment and some turbulence not modeled. However, the latest NACOK experiments work with a mass flow rate in the range where the model is in good agreement.

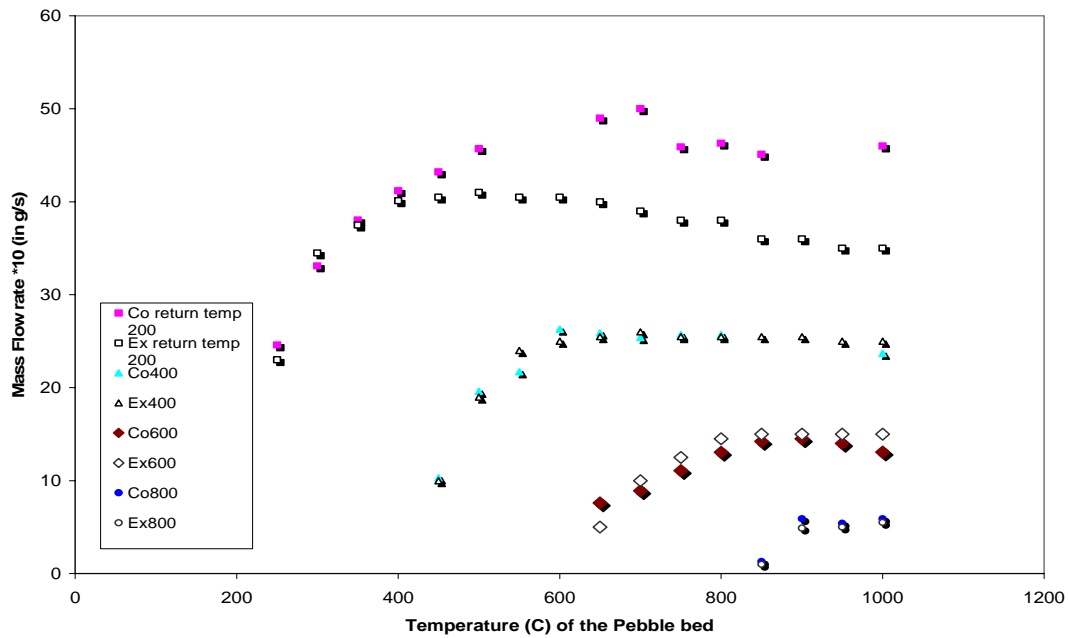

Figure 8
Comparison between Ex (Experiments) and Co (Computations) for the natural convection NACOK test: superficial velocity option

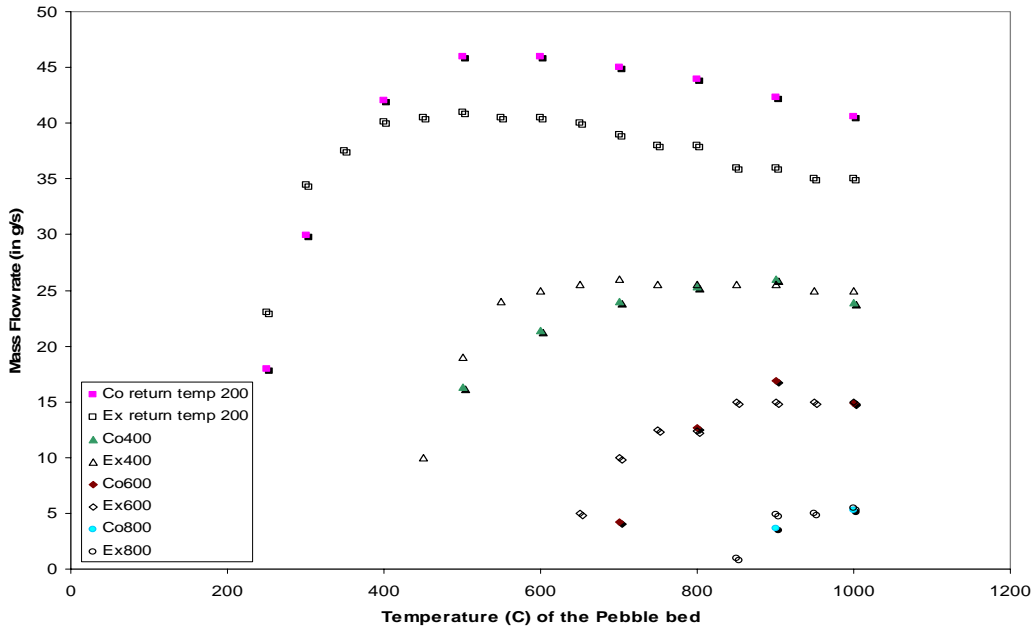

Figure 9
Comparison between Ex (Experiments) and Co (Computations) for the natural convection NACOK test: physical velocity option

VI.2 Natural Convection Flow in the NACOK Experiment (Open Chimney and Return Duct): Estimate of the Maximum Graphite Loss

In order to have an estimate of the mass flow rate and velocity in the NACOK experiments, simulations were run without chemical reactions activated. Therefore, no heat is being added by the graphite corrosion and the temperature stays at 650 degrees Celsius. However, as shown above, the mass flow rate calculated is in the right order of magnitude, since a variation of 600 C induces only a multiplication by 3 of the mass flow rate. According to information on the NACOK, temperature never exceeded 1500 C and therefore the flow rate will be in the same range as the one computed.

These calculations summarized on Table 1 yielded mass flow rates given no chemical reactions that would if taken in account, modify the temperature distribution. The air entering is composed of 21% mass of O₂. An estimate of the graphite mass loss can be made based on this mass flow rate computed with these simple assumptions. The maximum graphite corrosion rate is calculated with the extreme assumption that all the oxygen available will react with the carbon, and this, with a constant species ratio of 0.71 (0.71 mol of O₂ for 1 mol of C).

Table 1
Estimates of Maximum Graphite Loss

	Return Duct	Open chimney
Mass flow rate	0.0019 kg/s	0.00344 kg/s
O ₂ mass flow rate	0.437 g/s = 0.0136mol/s	0.791 g/s = 0.0247mol/s
Maximum Graphite corrosion rate	0.0192 mol/s = 0.230 g/s	0.0347 mol/s =0.417g/s
Maximum Graphite Mass loss in 24 h	6.64 kg	12 kg

VI.3 Graphite Corrosion Study on One Reflector

The complete model (entire set-up) needs a long time to converge if the model includes graphite corrosion. Shown on figure 9 is the detailed mesh description of the lower reflector area of the NACOK facility.

To study the effects of chemical corrosion, a simulation of chemical reaction on one reflector (96

channels of 8mm radius and 200 mm height) with imposed mass flow rate of 0.0036kg/s was made on FLUENT.

The case presented here is as follow: a reflector with detailed channels is initialized with 23% mol of O₂. The following graphs show the evolution of species mass fractions. The Boudouard reaction is not taken in account in these runs. The time steps are fixed at 0.5s, (60 time steps = 30s). Shown on figure 10 is the reflector segment as modeled in NACOK.

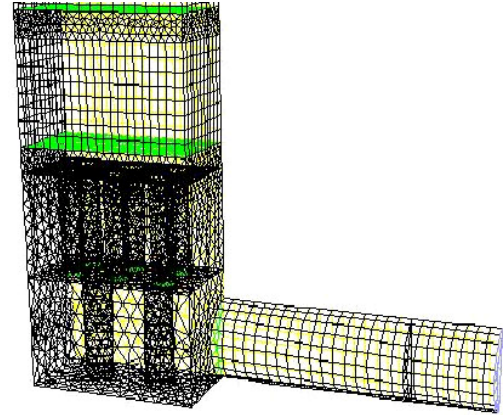

Figure 9
Details of the Grid for the Lower Part of the Chimney: The upper block is the 96 channel reflector modeled as a porous media.

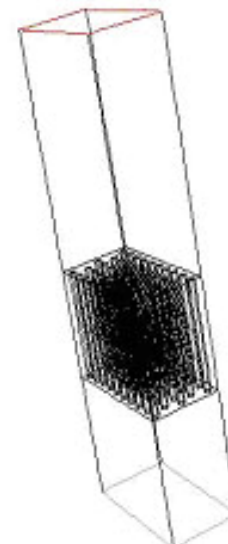
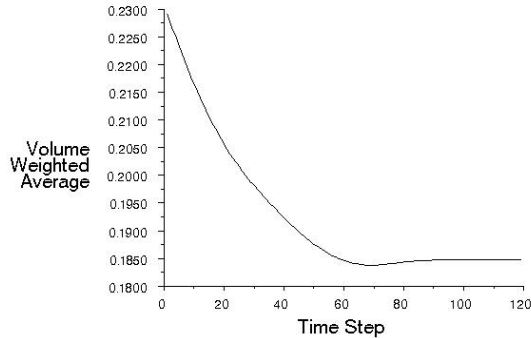

Figure 10
Grid Outline of the 96 Channel Reflector

The following Figures 11, 12, and 13 show the reflector volume weighted average oxygen, CO₂ and CO mass fractions as a function of time until steady state is reached



Convergence history of Mass fraction of o2 on tubes (Time=6.0000e+01) Jun 26, 2006
FLUENT 6.2 (3d, dp, segregated, spe, lam, unsteady)

Figure 11
O₂ Mass Fraction in Detailed Reflector
Equilibrium at 60s

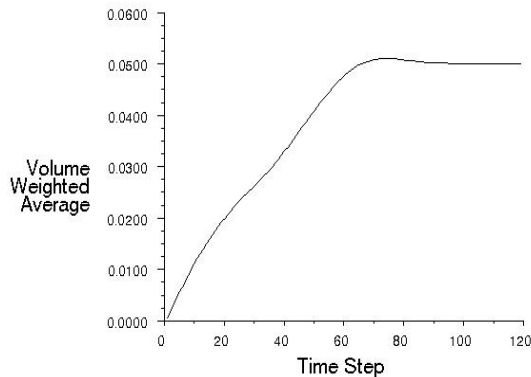

Convergence history of Mass fraction of co2 on tubes (Time=6.0000e+01) Jun 26, 2006
FLUENT 6.2 (3d, dp, segregated, spe, lam, unsteady)

Figure 12
CO₂ Mass Fraction in Detailed Reflector
(channels) Equilibrium at 60 s

A good estimate of what happens in the channel can therefore be deduced from these quick and simplified computations. We see that in this small volume, a chemical equilibrium is reached after 35 seconds of contact between graphite and oxygen. The graphite loss rate is 0.19g/s/m². It is much less than expected in the whole chimney configuration. Therefore, that implies that there will still be some oxygen that did not react exiting one reflector. The average mass

concentration ratios on a plane above the tubes are as follow: 12.9 % of O₂, 0.12% of CO and 14.1% CO₂. Therefore, we can deduce that two such reflectors will be sufficient to consume all the oxygen entering the experimental chamber and as such oxygen will not reach the pebble beds. Additionally, the mass ratio of CO is very small and therefore, so are the chances of CO combustion in the pebbles area. These preliminary analyses were necessary to establish the detailed analytical modeling approaches for this blind benchmark.

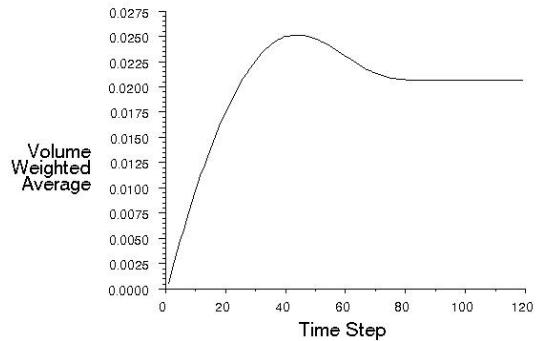

Convergence history of Mass fraction of co on tubes (Time=6.0000e+01) Jun 26, 2006
FLUENT 6.2 (3d, dp, segregated, spe, lam, unsteady)

Figure 13
CO mass fraction in detailed reflector (channels)
Equilibrium at 60s

VI.4 Blind Benchmarking of the Open Chimney Test Run in Steady State

Using the results and modeling procedures developed in the previous sections, the full NACOK simulation on the open chimney experiment was run. Based on the initial conditions provided by Juelich both a time dependent and steady state analyses were tested. The time dependent analyses as expected were quite time consuming but were run until it was determined that a steady state condition was being approached within the 480 minute maximum test time. Thus it was decided to run a steady state comparison since it ran much quicker. For the open chimney configuration test, the chemical reaction rates from Takeda and Hishida [8], with a fixed CO/CO₂ ratio of 0.58 was used.

Once the blind results were obtained they were sent to Juelich for review and comparison. Juelich

provided to MIT some data for comparison purposes. Not all data was provided from the experiment to allow for a more complete comparison to detailed FLUENT results. It is hoped that this will be done in the future for model refinement.

Parameter	FLUENT co.	NACOK exp
Time length	480 min	480 min
Mass flow rate	3.4 g/s	N.A.
Air entry	3.416 Kmol	3.413 Kmol
Graphite loss	8.943 kg	8.91 kg
Average O ₂ molar fraction	0.005	<0.1
Average CO molar fraction	0.01	<0.1
Average CO ₂ molar fraction	0.206	0.21

Table 2
Comparison between Computational and Experimental Parameters

Figure 14 and 15 show the distribution of temperature and species fractions. Please note that the scales for each are about 2 meters with the molar fraction final point extended to about 8 meters to show no change in concentrations over 5 meters. The key to understanding the difference in results will be reviewing the experimental data and obtaining, if possible a better description of the graphite chemical properties.

The main parameters in the experiment as well as the distribution of temperatures and species molar fraction as a function of height in the chimney are

shown on Table2, Figures 14 and 15. There is a good qualitative agreement for the temperature distribution. The computational results show higher temperatures distributed lower in the chimney. While the cause of this difference is not yet understood since detailed experimental data has not yet been available, it may be due to graphite reaction rates which are quite important in this analysis. For future analyses this data needs to be available for the particular graphite being used in the reactors.

VI.5 Discussion of the Open Chimney Tests Results

The results show generally good agreement with experimental data especially in the temperature prediction. However insufficient information is available at the present time regarding vertical CO/CO₂ concentrations to make detailed comparisons. At first inspection, it appears that the reaction of graphite oxidation occurs too fast in the model which results in the heat accumulating in the lower part of the reflector. Other chemical models need therefore to be applied in order to obtain a better agreement.

The NACOK experiment shows that all the oxygen is consumed in the lower reflector, either by the graphite corrosion reaction or the CO oxidation. FLUENT computations show a small increase in the CO molar fraction at the outlet. This needs to be checked with other reactions models, but can be explained by the fact that all the oxygen has been consumed in the lower parts. Therefore, the Boudouard reaction can explain the formation of a minor amount of CO which did not “find” oxygen to react. No data with respect to the chimney location were provided by the Julich center at this point.

The air velocity in the chimney varies depending on the flow diameter and medium type. However, it is never really high, (0.3 m/s at the inlet, 0.0813 m/s at the outlet). Higher velocities might occur in the pebble bed reactor, which would then modify the reaction rate.

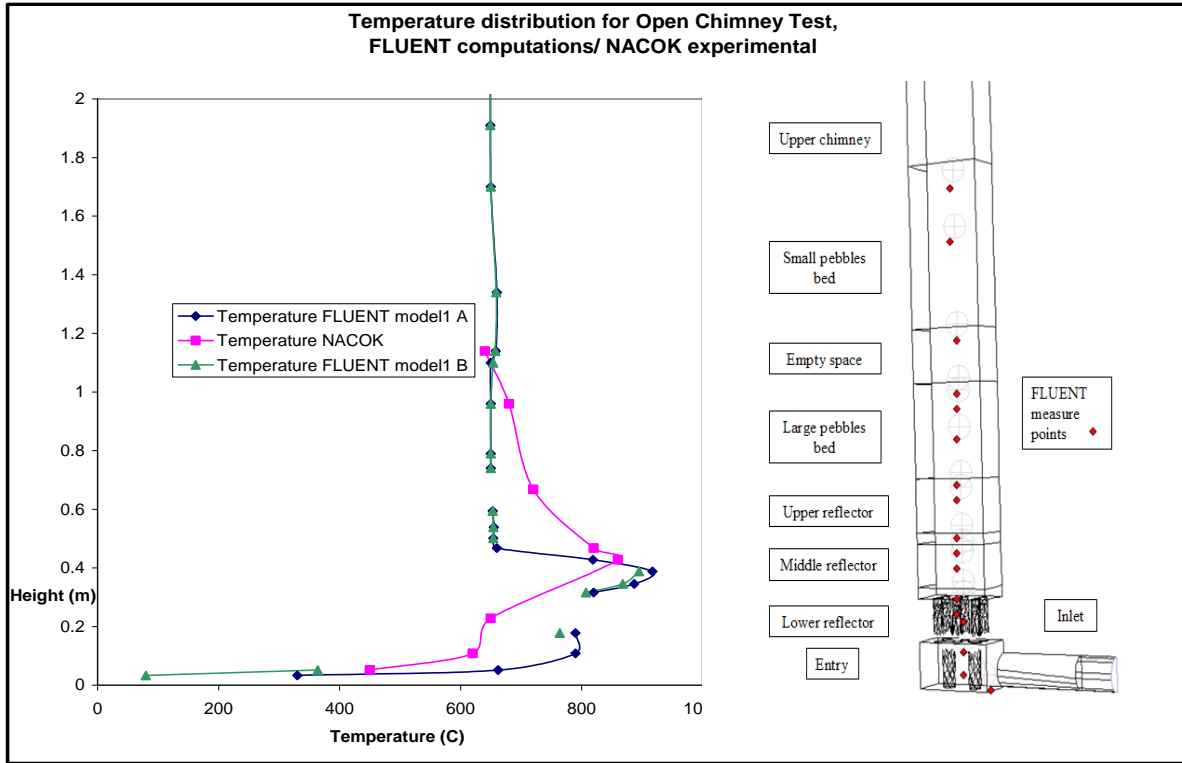

Figure 14
Temperature distribution in the open chimney test

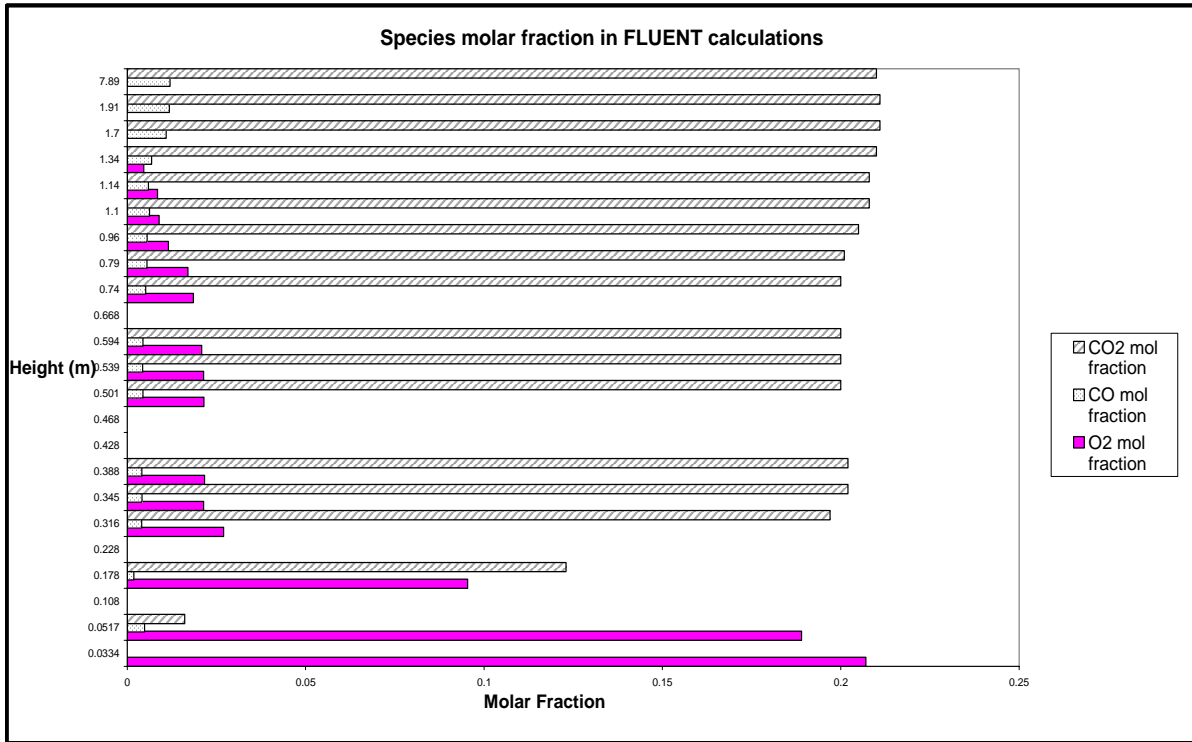

Figure 15
Molar fraction in the open chimney test

Summary and Conclusions:

Computational Fluid Dynamics modeling of the complex NACOK air ingress experiments is challenging due to the many different processes under way. In order to improve the success of the blind benchmark, preliminary tests and models were executed to test the functionality of the approach building on past air ingress modeling of relative simple geometries and conditions. Pressure drop correlations were developed for FLUENT that match Kuhlmann's original experimentally derived correlations that are suitable for use in FLUENT. An improved physical velocity flow model was benchmarked against past NACOK tests which should provide better representation of chemical reactions.

Chemical models using UDF's were incorporated in FLUENT and successfully executed in a reflector segment matching pebble surface to volume ratios in a porous media analysis.

The open chimney blind benchmark yielded quite reasonable results with respect to the experimental temperature data using the CFD modeling procedures developed. In order to better understand the differences, and the prediction of the chemical species generated, additional detailed experimental data will need to be analyzed. What the open chimney test has demonstrated is the importance in understanding the chemical properties of the graphite. Additional refinements will be made with additional data and simulations will be performed at higher but typical pebble bed operating temperatures - 900 C.

Analyses are now being performed with a hot and cold leg return duct using the methodologies developed. What will be significant is the timing of the onset of natural circulation. Since the open chimney test is more severe when it comes to assessing the impact of air ingress, there is some optimism that air ingress may not be a limiting transient for high temperature gas reactors.

VII. References

Main references cited in text:

- [1] FLUENT Inc.2006, "FLUENT 6.0 User's guide"
- [2]"German Safety Guide KTA3102.2 and KTA3102.3", German Nuclear Safety Standards Commission (1981)
- [3] Kuhlmann, M. B. "Experiments to investigate flow transfer and graphite corrosion in case of air ingress accidents in a high temperature reactor", Jul-4003, 2002.
- [4] Lim, H. and No, H., "GAMMA Multidimensional Multicomponent Mixture Analysis to predict Air Ingress Phenomena in an HTGR", Nuclear Science and Engineering, 152, 87-97, (2006)
- [5] Lim, H. and No, H., "Transient Multicomponent Mixture Analysis based on ice numerical scheme for predicting an air ingress phenomena in an HTGR", NURETH-10, Seoul, Korea, 2003
- [6] Moormann, R. and Hinssen H., "Transport and reaction of gaseous oxidants in porous nuclear carbons", Proceedings Int. CIMTEC-Conf. on Mass and Charge Transport in Inorganic Solids, Italy, 2000
- [7] Niessen, H, NACOK experiments report., Julich center, Germany, 2006.
- [8] T. Takeda and M Hishida, "Studies on molecular diffusion and natural convection in a multicomponent gas system", Int. J. Heat Mass Transfer. Vol. 39, No 3, pp. 527-536, 1996
- [9] Zhai, Tieliang, "LOCA and Air Ingress Accident Analysis of a Pebble Bed Reactor", Massachusetts Institute of Technology, Nuclear Science and Engineering dpt. 2003.

Other references used:

- [10] A.C Kadak, R.G. Ballinger, "Modular Pebble Bed Reactor Project, Fourth Annual Report" MIT – ANP-PR-094, December 2002
- [11] Hirschfelder, "Molecular Theory of Gases and liquids", John Wiley and sons inc, 1954
- [12] C.T Shaw, "Using Computational Fluid Dynamics", Prentice Hall, 1992

[13] “Psychrometric chart”, Nautica dehumidifiers inc.

[14] C.J. Lea, “Guidance for NSD on the assessment of CFD simulations in safety cases”, Health and safety laboratory, 1997

[15] M Weightman, “Validation of computer codes and calculational methods”, Nuclear Safety Directorate, 2003

[16] Moormann, R. and Hinssen H., “Oxidation behavior of carbon based materials used for high-temperature gas-cooled reactors and fusion reactors”, Proceedings Int.9th CIMTEC-Conf., Italy, 1998

[17] E.L. Fuller, J.M. Okoh, “Kinetics and mechanisms of the reaction of air with nuclear grade graphites: IG-110”, J. of Nuclear Materials 240 (1997) p241-250.

[18] M.W Rosenhow, P.J. Hartnett, “Handbook of heat transfer” 1973.

[19] R.B Bird, W.E Stewart and E.N Lightfoot, “Transport phenomena”, John Wiley and sons, NY, 1960.

[20] R.E. Nightingale, “Nuclear graphite”, Handford laboratories, GE Company, Academic press, 1992.

[21] M.L. Dams, “Simulation of the pebble bed modular reactor natural air convection passive heat removal system”, Integrators of System Technology Ltd, Waterkloof, South Africa.

[22] M. Takahashi, M. Kotaka and H. Sekimoto, “Burn-off and production of CO and CO₂ in the oxidation of nuclear reactor grade graphites in a flow system” J. of Nuc. Science and Technology, Vol.31, no 12 pp 1275-1286, 1994.

[23] Luo Xiaowei, J.C. Robin, Yu Suyuan, “Effect of temperature on graphite oxidation behavior”, Nuc. Eng. and Design 227 (2004) 273-280

[24] I.E Idelchik, M.O Steinberg, “Handbook of hydraulic resistance”, CRC pr, 3rd edition, 1994

[25] M. Rossberg, Z. Elektrochem, Vol 60 pp 952 1956